

Features

- : 670nm wavelength range
- : Operating to over 50 °C
- : Low current and voltage
- : High reliability
- : Other configurations available on request

Applications

- : Consumer Electronics
- : Position Sensors
- : Medical Instruments
- : Home Networking
- : Data Link Communication, IEEE1394b
- : Low power consumption application
such as battery-operated equipment

Description

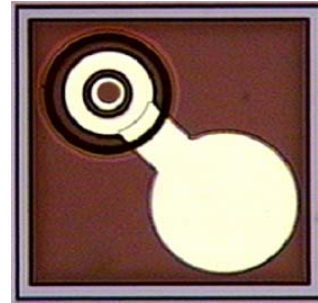

Absolute Maximum Ratings

Parameter	Rating
Storage Temperature	-40 to 85 °C
Operating Temperature	-20 to 50 °C
Lead Solder Temperature	260 °C, 10 sec
Continuous Forward Current	8 mA
Continuous Reverse Voltage	5V (@10μA)

Dimensions

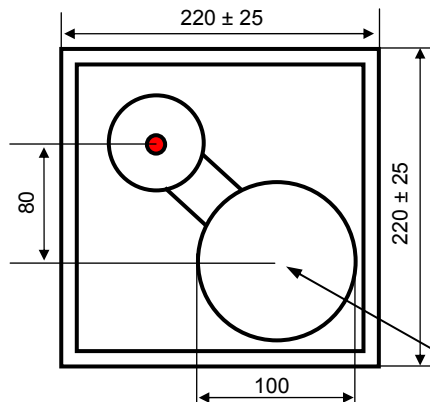

Unit: μm
Die Height: 200±15 μm

Anode Bonding Pad (Φ 100 μm)

Electro-Optics Characteristics (T_a=25°C unless otherwise stated)

Parameters	Symbol	Specified			Unit	Test Conditions
		Min.	Typ.	Max.		
Threshold Current	I _{th}		2	3.5	mA	CW
Slope Efficiency	η	0.2	0.4		W/A	I _f = 5mA
Optical Output Power	P _o		1.0		mW	I _f = 5mA
Peak Wavelength	λ	660	670	690	nm	I _f = 5mA
Spectral Bandwidth (RMS)	Δλ			0.85	nm	I _f = 5mA
Beam Divergence	Θ	14		30	°	P ₀ =1.0mW, (Full Width, 1/e ²)
Operating Voltage	V _f		2.1	2.5	V	I _f = 5mA
Dynamic Resistance	R _d		60	80	Ohm	I _f = 5mA

Thermal Characteristics

Parameters	Symbol	Min.	Typ.	Max.	Unit	Test Conditions
Max. Operating Temperature						
Optical Output Power	P _{T=50°C}		0.5		mW	T _a = 50 °C, 5mA
I _{th} Temperature Variation	ΔI _{th}		1.5		mA	T _a = -20 to 50 °C
η Temperature Variation	Δη / ΔT		-0.8		%/ °C	T _a = -20 to 50 °C at 5mA
λ Temperature Variation	Δλ / ΔT		0.05		nm/ °C	T _a = -20 to 50 °C at 5mA

Notes

* These specifications are subject to change without notice.

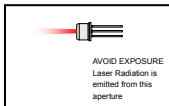
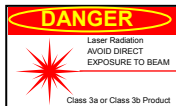

NOTICE

The inherent design of this component causes it to be sensitive to electrostatic discharge(ESD). To prevent ESD-induced damage and/or degradation to equipment, take normal ESD precautions when handling this product

DANGER

The VCSEL is a class IIIb laser and should be treated as a potential eye hazard. Due to the size of the component, the applicable warning logotype, aperture label, and certification / identification label cannot be placed on the component itself.

Characteristics Curves

LIV Curve

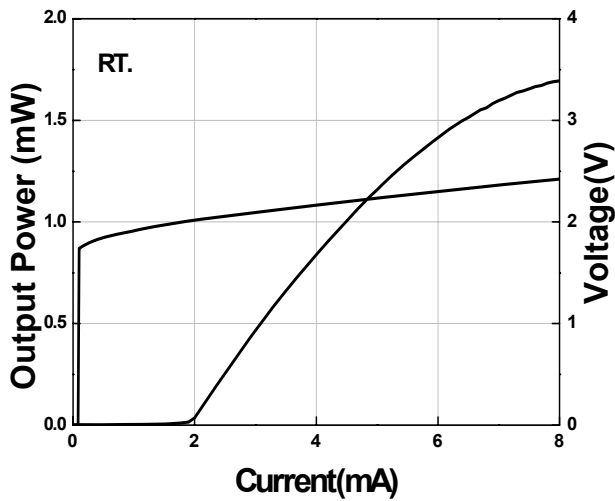

LIV vs Temperature

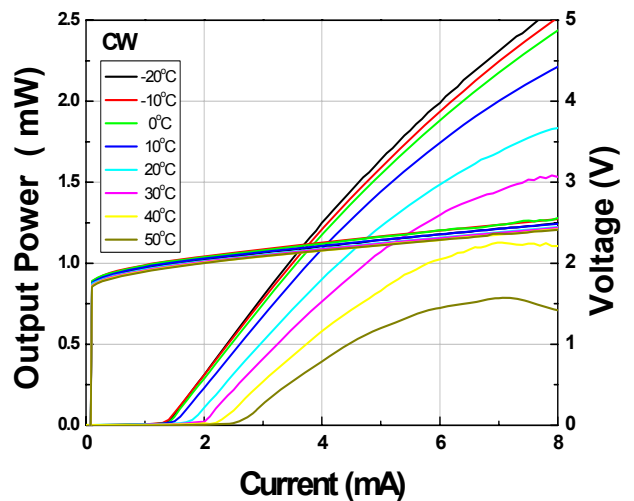

I_{th} vs Temperature

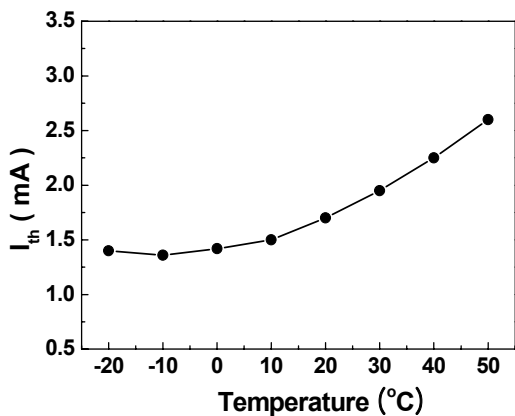

P_o vs Temperature

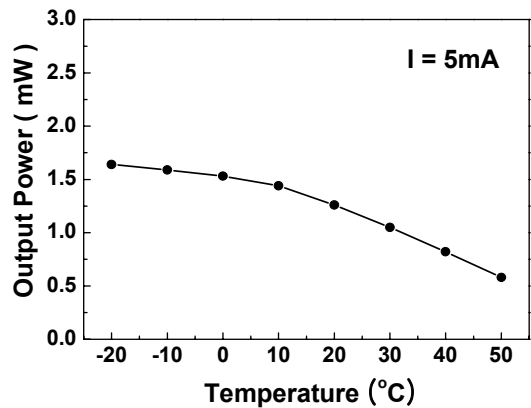

Far Field Pattern

