

Features

- : 980nm wavelength range
- : High data rate 1.25 / 2.5Gbps
- : High reliability
- : Low current and voltage
- : Other configurations available on request

Applications

- : High speed Data Communications
- : Gigabit Ethernet
- : Fiber Channel

Description



Absolute Maximum Ratings

Parameter	Rating
Storage Temperature	-40 to 100 °C
Operating Temperature	0 to 85 °C
Lead Solder Temperature	260 °C, 10 sec
Continuous Forward Current	12mA
Continuous Reverse Voltage	5V (@10µA)

Dimensions

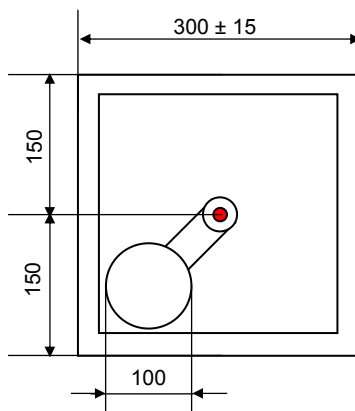

Unit: µm
Die Height: 200±15 µm

Electro-Optics Characteristics (T_a=25°C unless otherwise stated)

Parameters	Symbol	Specified			Unit	Test Conditions
		Min.	Typ.	Max.		
Threshold Current	I _{th}		1.5		mA	CW
I _{th} Temperature Variation	ΔI _{th}		1.5		mA	T _a =0 to 85 °C
Slope Efficiency	η	0.2	0.3	0.5	W/A	I _f = 6mA
η Temperature Variation	Δη / ΔT		-0.5		%/ °C	T _a =0 to 85 °C at 6mA
Optical Output Power	P _o		1.5		mW	I _f = 6mA
Peak Wavelength	λ	970	980	990	nm	I _f = 6mA
λ Temperature Variation	Δλ / ΔT		0.06			T _a =0 to 85 °C at 6mA
Spectral Bandwidth (RMS)	Δλ			0.85	nm	I _f = 6mA
Beam Divergence	Θ	14		30	°	P ₀ =1.5mW, (Full Width, 1/e ²)
Operating Voltage	V _f		1.6	2.0	V	I _f = 6mA
Breakdown Voltage	V _b		-10		V	
Dynamic Resistance	R _d	25	35	55	Ohm	I _f = 6mA

Notes

1. High power or sub-milliamper threshold current can be provided under request.
2. Tighter wavelength specifications are available on request.
3. Our technological team have amassed a wealth of experience in the development of the epitaxy and processing of VCSELs. If you have a specific application for a VCSEL, please call or e-mail. One of our specialists will be happy to discuss your particular requirements

* These specifications are subject to change without notice.

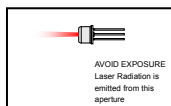
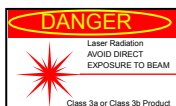

NOTICE

The inherent design of this component causes it to be sensitive to electrostatic discharge(ESD). To prevent ESD-induced damage and/or degradation to equipment, take normal ESD precautions when handling this product

DANGER

The VCSEL is a class IIIb laser and should be treated as a potential eye hazard. Due to the size of the component, the applicable warning logotype, aperture label, and certification / identification label cannot be placed on the component itself.

Characteristics Curves

