

Features
<ul style="list-style-type: none"> : Multi-mode 850nm VCSEL : 2.5 Gbps data rates : Low drive current and voltage : Eextended operating temperature range : Other configurations available on request

Description



Applications
<ul style="list-style-type: none"> : High speed Data Communications : Gigabit Ethernet : Fiber Channel

Absolute Maximum Ratings	
Parameter	Rating
Storage Temperature	-40 to 100 °C
Operating Temperature	-40 to 85 °C
Lead Solder Temperature	260 °C, 10 sec
Continuous Forward Current	12mA
Continuous Reverse Voltage	5V (@10µA)

Part Number :	Description :
TP85-SCP1NW-KC	850nm 2.5Gbps SC TOSA, Common Cathode Type
TP85-SCP1NW-AC	850nm 2.5Gbps SC TOSA, Common Anode Type

Dimensions

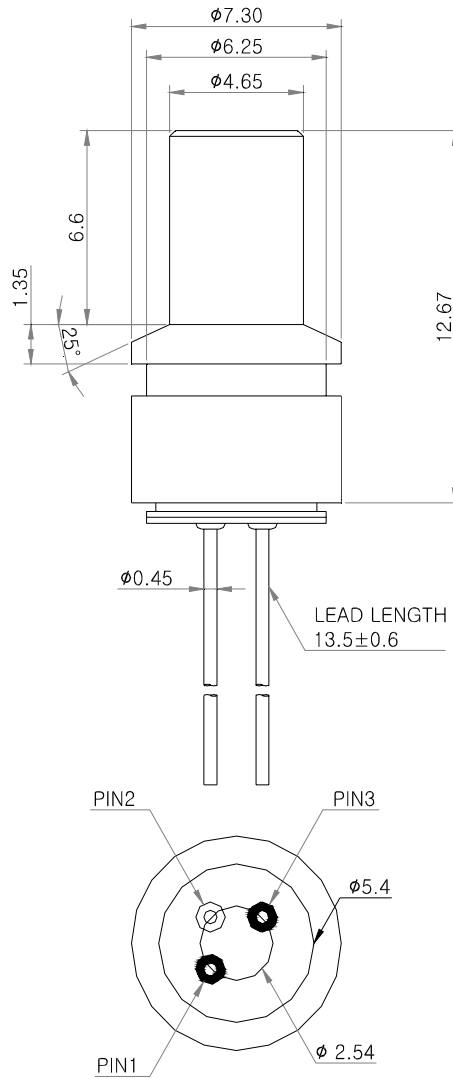
Unit :mm



Bottom View

PIN OUT

TP85-SCP1NW-KC		TP85-SCP1NW-AC	
Number	Function	Number	Function
1	A_{VCSEL}	1	K_{VCSEL}
2	K_{VCSEL}, A_{m-PD}	2	A_{VCSEL}, K_{m-PD}
3	K_{m-PD}	3	A_{m-PD}

Electro-Optics Characteristics ($T_a=25^\circ\text{C}$ unless otherwise stated)

Parameters	Symbol	Specified			Unit	Test Conditions
		Min.	Typ.	Max.		
Peak Fiber Coupled Optical Output Power (See threshold current And slope efficiency which Control power output)	P_{OC}		500		μW	$I_f = 7\text{ mA}, 50/125\ \mu\text{m fiber NA}=0.20$
Threshold Current	I_{th}		1.0	2.5	mA	CW
I_{th} Temperature Variation	ΔI_{th}		2	3	mA	$T_a = -40\text{ to }85\ ^\circ\text{C}$
Slope Efficiency	η	0.04		0.16	W/A	$I_f = 7\text{ mA}$
η Temperature Variation	$\Delta\eta / \Delta T$		-5000		PPM/ $^\circ\text{C}$	$T_a = -40\text{ to }85\ ^\circ\text{C}$ at 7 mA
Peak Wavelength	λ_P	840	850	860	nm	$I_f = 7\text{ mA}$
λ_P Temperature Coefficient	$\Delta\lambda / \Delta T$		0.06		nm/ $^\circ\text{C}$	$T_a = -40\text{ to }85\ ^\circ\text{C}$ at 7 mA
Spectral Bandwidth (RMS)	$\Delta\lambda$			0.85	nm	$I_f = 7\text{ mA}$
Forward Voltage	V_f		1.7	2.2	V	$I_f = 7\text{ mA}$
Breakdown Voltage	V_b		-10		V	-
Rise and Fall Times	t_R			130	ps	Prebias Above Threshold, 20%~80%
	t_F			150		
Relative Intensity Noise	RIN		-130	-122	dB/Hz	1 GHz BW, $I_f = 7\text{ mA}$
Series Resistance	R_s	20	35	55	Ohm	$I_f = 7\text{ mA}$
R_s Temperature Coefficient	dR_s/dT		-3000		PPM/ $^\circ\text{C}$	-

Parameters	Symbol	Min.	Typ.	Max.	Unit	Test Conditions
Monitor Current	I_{PD}	0.2		0.7	mA	$P_{OC}=0.5\text{mW}$
Dark current	I_D			10	nA	$P_o=0\text{mW}, V_R=5\text{V}$
PD Reverse Voltage	BVR_{PD}	40			V	$P_o=0\text{mW}, I_R=100\ \mu\text{A}$
PD Capacitance	C			50	pF	$V_R=0\text{V}, \text{Freq}=1\text{MHz}$
				20		$V_R=5\text{V}, \text{Freq}=1\text{MHz}$

Notes

* These specifications are subject to change without notice

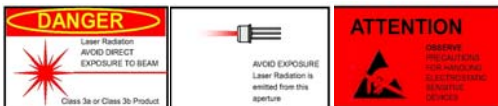

NOTICE	The inherent design of this component causes it to be sensitive to electrostatic discharge(ESD). To prevent ESD-induced damage and/or degradation to equipment, take normal ESD precautions when handling this product
DANGER	The VCSEL is a class IIIb laser and should be treated as a potential eye hazard. Due to the size of the component, the applicable warning logotype, aperture label, and certification / identification label cannot be placed on the component itself.