

**Features**

- : 670nm wavelength range
- : Operating to over 50 °C
- : Low current and voltage
- : High reliability
- : Other configurations available on request

**Description**

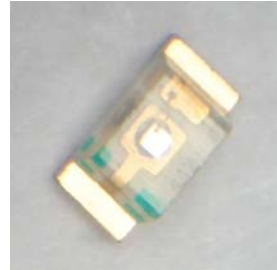

**Applications**

- : Consumer electronics
- : Position Sensors
- : Medical Instruments
- : Home Networking
- : Data Link Communication, IEEE1394b
- : Low power consumption application such as battery-operated equipment

**Absolute Maximum Ratings**

Parameter	Rating
Storage Temperature	-40 to 85 °C
Operating Temperature	-20 to 50 °C
Lead Solder Temperature	260 °C, 5 sec
Continuous Forward Current	8mA
Continuous Reverse Voltage	5V (@10µA)

Dimensions

Unit :mm

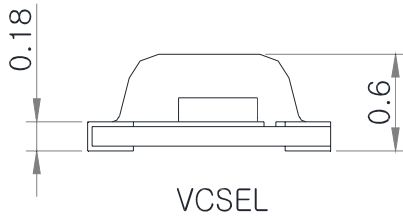
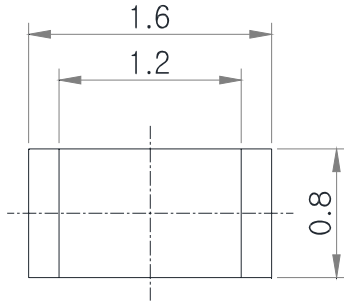

For Reflow Soldering

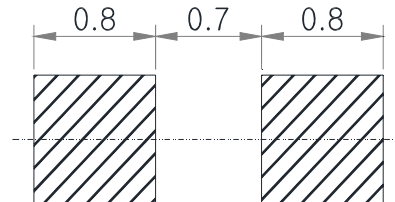

**Electro-Optics Characteristics ( $T_a=25^\circ\text{C}$  unless otherwise stated)**

Parameters	Symbol	Specified			Unit	Test Conditions
		Min.	Typ.	Max.		
Threshold Current	$I_{th}$		2	3.5	mA	CW
Slope Efficiency	$\eta$	0.2	0.4		W/A	$I_f = 5\text{mA}$
Optical Output Power	$P_o$		1.0		mW	$I_f = 5\text{mA}$
Peak Wavelength	$\lambda$	660	670	690	nm	$I_f = 5\text{mA}$
Spectral Bandwidth (RMS)	$\Delta \lambda$			0.85	nm	$I_f = 5\text{mA}$
Beam Divergence	$\Theta$	14		30	$^\circ$	$P_0=1.0\text{mW}$ , ( Full Width, $1/e^2$ )
Operating Voltage	$V_f$		2.1	2.5	V	$I_f = 5\text{mA}$
Dynamic Resistance	$R_d$		60	90	Ohm	$I_f = 5\text{mA}$

**Notes**

\* These specifications are subject to change without notice

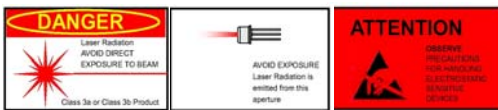

<b>NOTICE</b>	The inherent design of this component causes it to be sensitive to electrostatic discharge(ESD). To prevent ESD-induced damage and/or degradation to equipment, take normal ESD precautions when handling this product
<b>DANGER</b>	The VCSEL is a class IIIb laser and should be treated as a potential eye hazard. Due to the size of the component, the applicable warning logotype, aperture label, and certification / identification label cannot be placed on the component itself.